

FABER

Living the Italian Style

FOOD PROCESSOR INSTRUCTION MANUAL FCB 1030

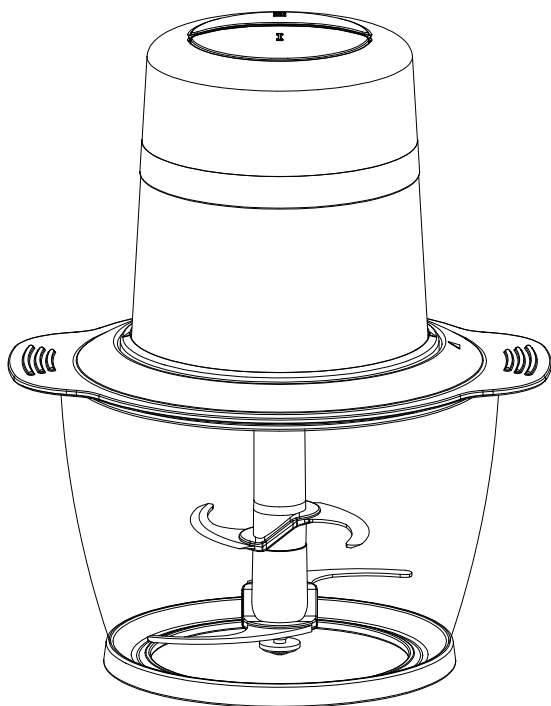

Read this booklet thoroughly before using and save it for future reference

IMPORTANT SAFETY INSTRUCTIONS

- Read all instructions before using.
- Do not open until blades stop.
- The attached motor unit can not be used for other than intended use.
- Unplug from the outlet when not in use and before cleaning. Allow to cool before putting on or taking off parts, and before cleaning the appliance.
- Do not let the cord hang over the edge of a table or counter or touch a hot surface.
- Do not place on or near a hot gas or electric burner or in a heated oven.
- keep hands and utensils away from the cutting blade while chopping food to reduce the risk of severe injury to persons or damage to the food chopper. A scraper may be used but only when the food chopper is not running.
- To protect against a fire, electric shock or personal injury, do not immerse cord, electric plugs, or motor unit in water or other liquids.
- Close supervision is necessary when any appliance is used by or near children.
- The appliance is not a toy. Do not let the children play it.
- Avoid contacting moving parts.
- The use of attachments not recommended or sold by manufacturer may cause fire, electric shock or injury.
- Do not operate any appliance with a damaged cord or plug or after the appliance malfunctions, or is dropped or damaged in any manner, Return appliance to the nearest authorized service facility for examination, repair or electrical or mechanical adjustment.
- Do not use the appliance for other than intended use.
- Be sure motor unit is locked securely in place before operating appliance.
- Do not attempt to defeat the lid interlock mechanism.
- Do not use outdoors.
- If the supply cord is damaged, it must be replaced by the manufacturer, its service agent or similarly qualified persons in order to avoid a hazard.
- Always disconnect the appliance from the supply if it is left unattended and before assembling, disassembling or cleaning.
- Appliance can be used by persons with reduced physical, sensory or mental capabilities or lack of experience and knowledge if they have been given supervision or instruction concerning use of the appliance in a safe way and understand the hazards involved.
- Children shall not play with the appliance.

- Appliance shall warn of potential injury from misuse.
- This appliance shall not be used by children. Keep the appliance and its cord out of reach of children.
- Care shall be taken when handling the sharp cutting blades, emptying the bowl and during cleaning.
- **SAVE THESE INSTRUCTION.**

DO NOT OPEN UNTIL BLADES STOP.

HOUSEHOLD USE ONLY

KNOW YOUR FOOD CHOPPER

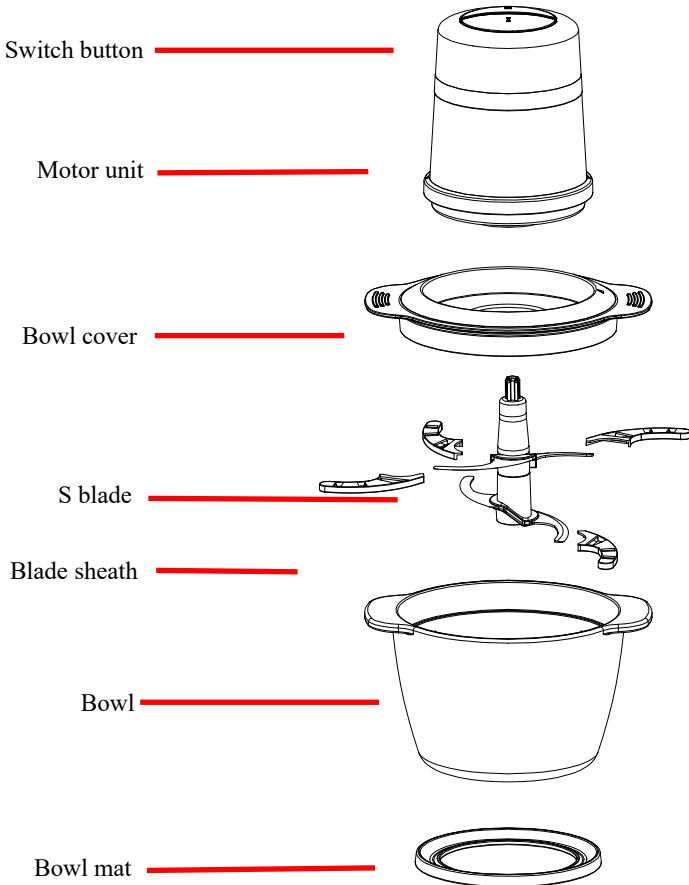

BEFORE THE FIRST USE

Before using this appliance for the first time, wash the bowl and blade assembly in sudsy water and dry thoroughly, all of these parts are safe in dishwasher, wipe the motor unit with a damp cloth, do not immerse the motor unit in water.

HOW TO CHOP OR MINCE FOOD

1. Place the bowl on a counter or other flat surface, then slide the blade down over the shaft in the bowl. Be careful not to touch the blade as it is extremely sharp.
2. Place food in the bowl, the desired food refers to the chopping guide.
3. Place the bowl cover onto the bowl then position the motor unit onto the bowl, the embossment on the bowl cover is linked up to the hole on the motor unit, lining up the motor unit locking tabs to the bowl locking slots till the motor unit locks.
4. Plug the power cord, the left hand hold the motor unit, then the right hand depress and hold the pulse button to process.
Note: This product has a pulse button. Avoid running the motor continuously in this mode for period over 30s. the longer the continuous pulse, the finer the texture. For coarsely chopped foods, use short pulses.
5. Be sure the blade stops rotating completely before removing the bowl cover. Unplug the unit. Remove the motor unit and grasp the plastic blade hub. carefully pull the blade assembly out. Remove the bowl and empty the processed food. Do not use bowl for storing food.

CLEANING AND MAINTENANCE

Always disconnect the appliance from the power outlet before cleaning.

Wash the bowl, blade assembly immediately after use either with warm/sudsy water or in the dishwasher. Wipe off the motor unit with a damp cloth- do not immerse in water.

NOTE: Do not use chemical, steel, wooden or abrasive cleaners to clean the unit to prevent the gloss loss.

CHOPPING GUIDE

Food type	Operation guide
Bread	Shred proper amount of bread into small pieces, it is recommended to use speed2 pulse to chop, work for 10 seconds, rest for 1 minute for one cycle, and perform several cycles of operation until a satisfactory chopping effect is achieved;
Fruits and Vegetables (canned, cooked)	Put up to 120g of food, it is recommended to use speed2 pulse to chop, work for 10 seconds, rest for 1 minute for one cycle, and perform several cycles of operation until a satisfactory thick slurry effect is achieved;
Fresh celery and other leafy plants	Put a proper amount of food to be thoroughly cleaned and dry, it is recommended to use speed2 pulse to chop, work for 10 seconds, rest for 1 minute for one cycle, and perform several cycles of operation until a satisfactory chopping effect is achieved;
Nut	Put up to 120g of food, it is recommended to use speed2 pulse to chop, work for 10 seconds, rest for 1 minute for one cycle, and perform several cycles of operation until a satisfactory thick slurry effect is achieved;
Cookies, cookies	Put up to 120g of food, it is recommended to use speed2 pulse to chop, work for 10 seconds, rest for 1 minute for one cycle, and perform several cycles of operation until a satisfactory thick slurry effect is achieved;
Fresh beef 60mm*20mm*20mm size block	Put up to 120g of food, it is recommended to use speed2 pulse to chop, work for 10 seconds, rest for 1 minute for one cycle, and perform several cycles of operation until a satisfactory thick slurry effect is achieved;
Honey,maltose	Put in 50 grams of honey and 50 grams of maltose, it is recommended to use speed 2 pulse to chop, work for 5 seconds,rest for 1 minute for one cycle, and perform several cycles of operation until a satisfactory thick slurry effect is achieved;

Environment friendly disposal

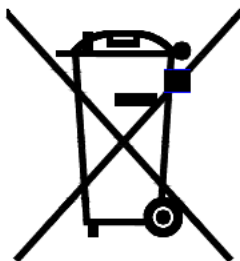

You can help protect the environment!
Please remember to respect the local regulations: hand in the non-working electrical equipments to an appropriate waste disposal center.

